

ASSEMBLY INSTRUCTIONS

SOLO BED BY NERI&HU

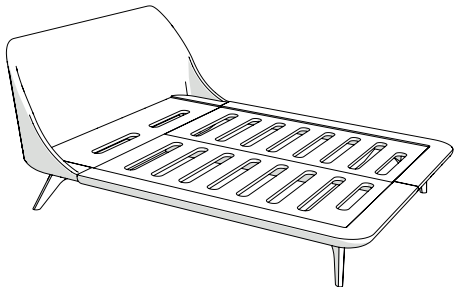

PARTS

- 1x headboard
- 2x platforms
- 1x cross beam
- 4x feet

HARDWARE

(4x) M8x35 countersunk screws



(4x) M8x45 countersunk screws



(14x) M8x60 countersunk screws



(8x) M8x60 silver socket cap screws



(8x) M8 washers



YOU WILL NEED

- 6mm Allen Key
- 5mm Allen Key
- The help of two friends

NOTES

NOTE 1: Be certain that all assembly is carried out on a flat and stable surface. This will ensure a good final result. Reverse the steps to disassemble the piece.

NOTE 2: Your furniture arrives packed in numerous layers that protect it during transport. It is important that you remove the packaging carefully to avoid damaging your furniture. Refer to our information sheet "Unpacking Your Furniture" for further details.

NOTE 3: Great care is required when assembling our products. Use blankets to soften the assembly surface - hard surfaces such as wood or stone flooring may damage the furniture if in direct contact.

NOTE 4: We advise that assembly and disassembly is undertaken by a minimum of 3 people: 2 to support the frame/assembly while 1 fixes the screws, and all to flip the bed in the final step.

O
1
N
E
R
I
&
H
U

ASSEMBLY INSTRUCTIONS CONTINUED

SOLO BED

NOTE 5: When screwing in bolts, tighten well, but be sure NOT TO OVERTIGHTEN. This can cause the thread to strip thus resulting in a poor connection.

NOTE 6: All mating parts are numbered so they correspond to the appropriate part around the frame of the bed. you will ensure the best possible fit if all parts are mated with the corresponding numbered parts. While you work, be sure all connections are flush with no gaps.

NOTE 7: If you do not have enough vertical space to assemble the bed on its back, it can be assembled upside down instead. This will make it more challenging to flip the bed in the final step.

INSTRUCTIONS

1) ATTACH PLATFORMS TO HEADBOARD

- a) Place the headboard on its back onto the floor.
- b) Attach one platform at a time, guiding the central beam into the central channel in the headboard. Insert four M8x60 countersunk screws into the pre-drilled holes where the two meet. Insert one M8x45 countersunk screw into the central beam along that same lip, and one M8x35 countersunk screw into the furthest end of the central beam. Tighten all connections firmly with an Allen Key.

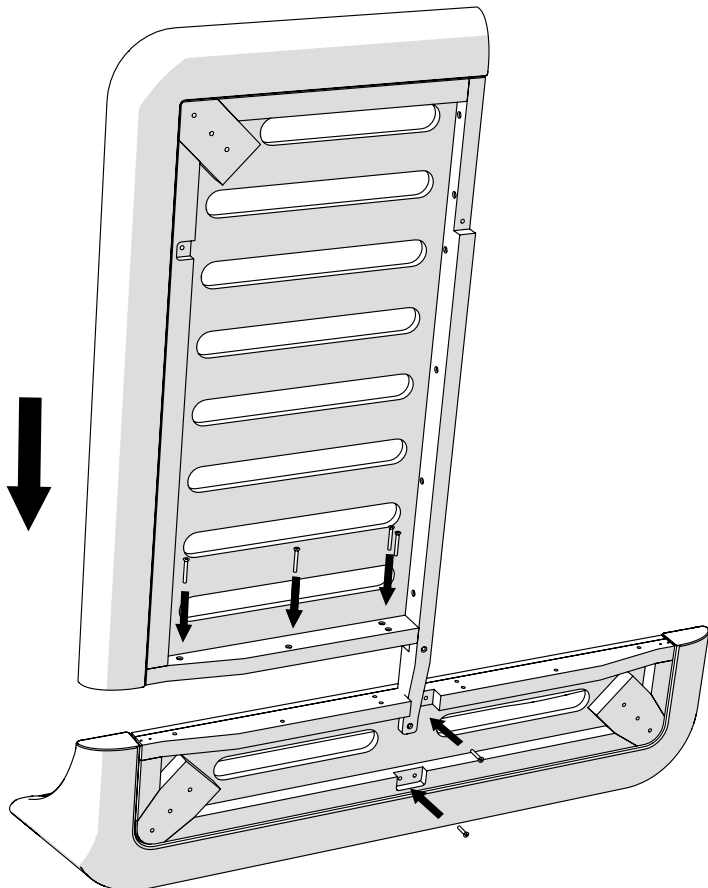

0
2
N
E
R
I
&
H
U

ASSEMBLY INSTRUCTIONS CONTINUED
SOLO BED

c) Repeat step B to attach the second platform.

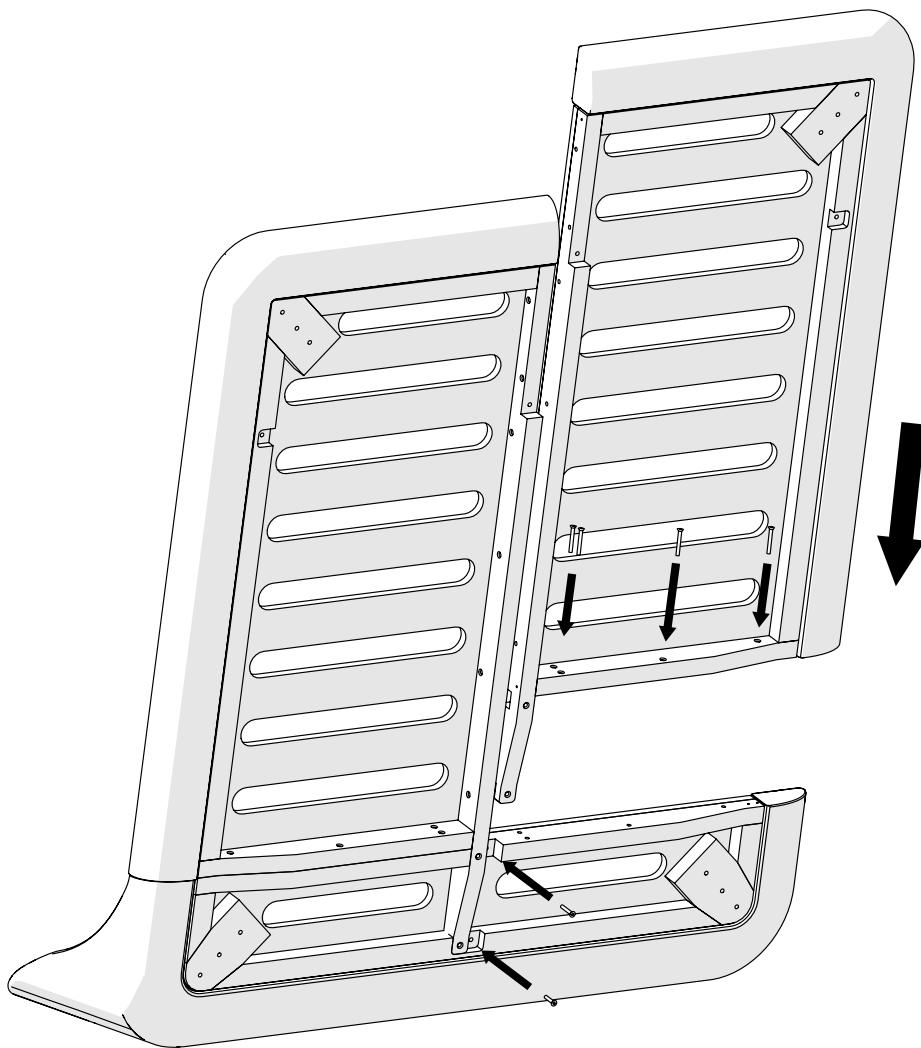

0
3
N
E
R
I
&
H
U

ASSEMBLY INSTRUCTIONS CONTINUED

SOLO BED

2) ATTACH THE PLATFORMS TO ONE ANOTHER

a) Insert an M8x60 countersunk screw into each of the pre-drilled holes where the two platforms meet one another. Tighten firmly with an Allen Key.

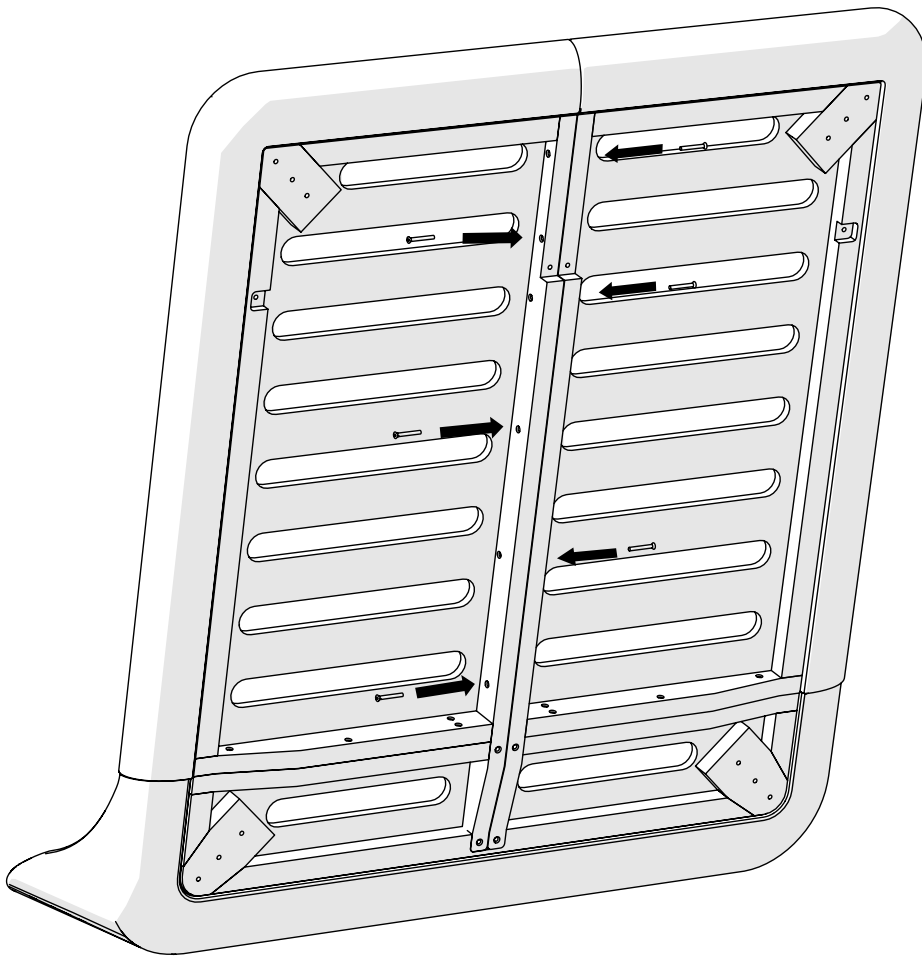

0
4
N
E
R
I
&
H
U

ASSEMBLY INSTRUCTIONS CONTINUED

SOLO BED

3) ATTACH CROSS BEAM

a) Place the cross beam onto the assembly, checking number markings for correct orientation. Insert one M8x35 countersunk screw into the pre-drilled hole in either end of the cross beam. Insert one M8x45 countersunk screw into each of the two holes at the centre of the cross beam. Tighten all connections firmly with an Allen Key.

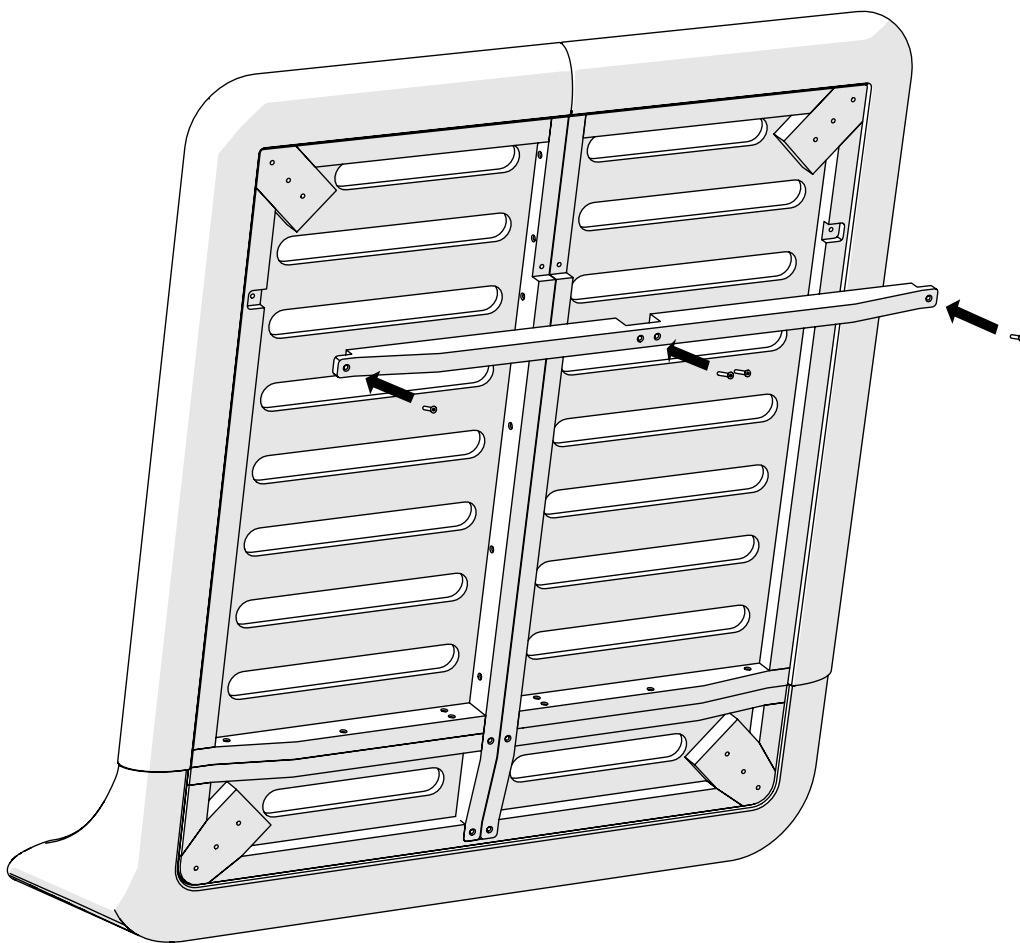

0
5
N
E
R
I
&
H
C

ASSEMBLY INSTRUCTIONS CONTINUED

SOLO BED

4) ATTACH FEET

a) Place a wooden foot onto each corner of the assembly, being sure to align the pre-drilled holes.

b) Insert two M8x60 silver socket cap screws and washers through each foot and into the subframe and tighten with an Allen key.

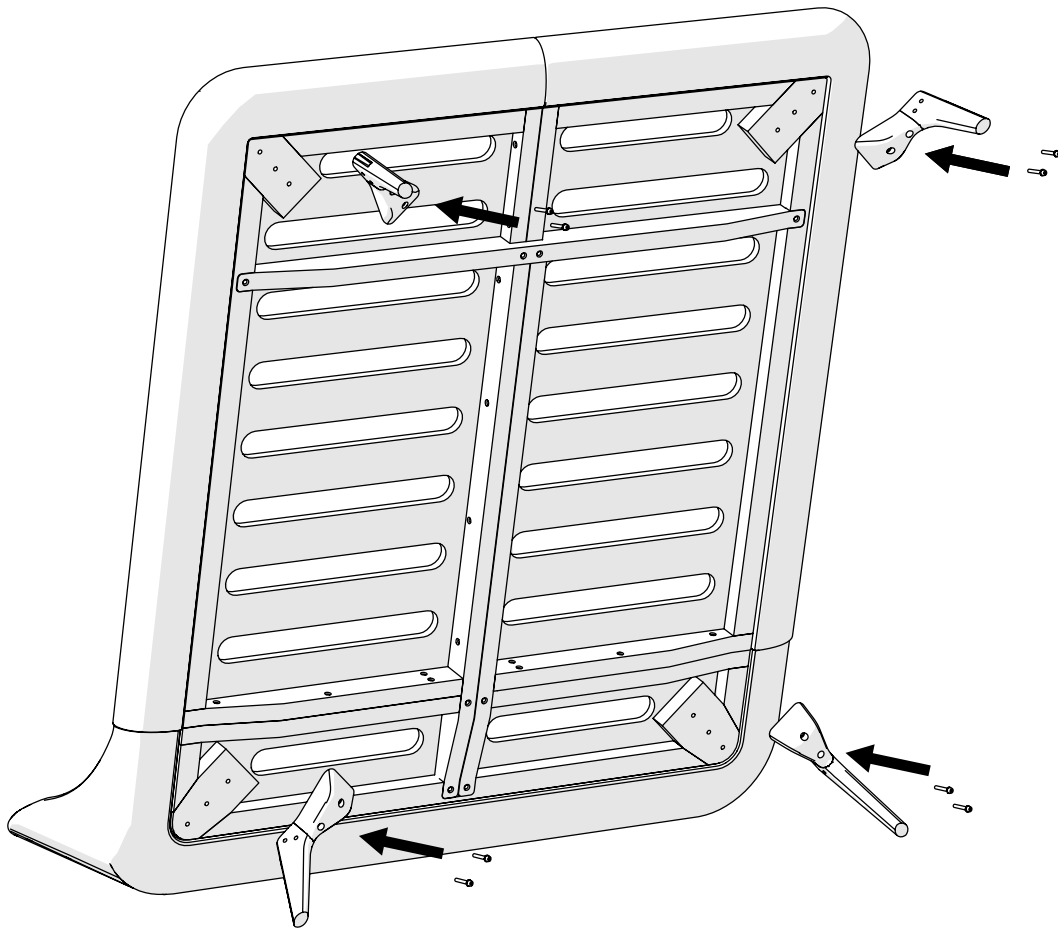

0
6
N
E
R
I
&
H
U

ASSEMBLY INSTRUCTIONS CONTINUED

SOLO BED

4) FLIP BED INTO UPRIGHT POSITION

a) With the help of two friends, turn the bed over into its natural upright position, being careful not to rest it on the feet while flipping.

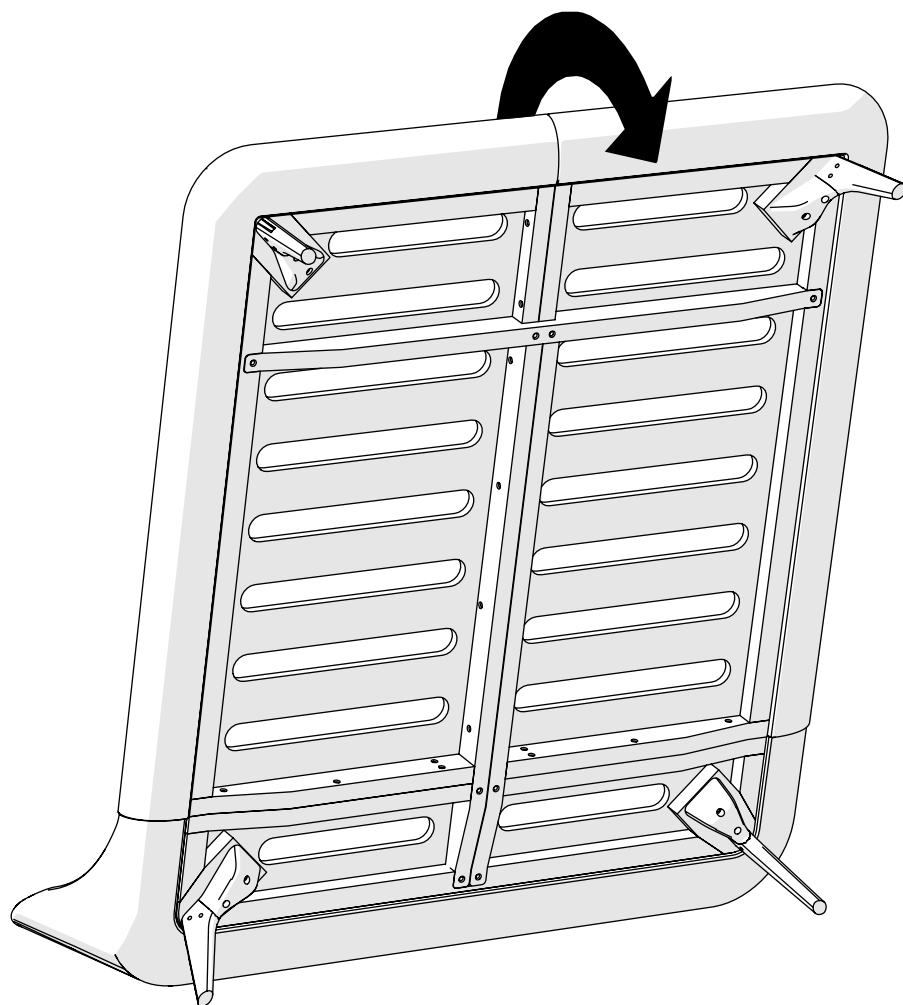

0

7

N

E

R

I

&

H

U

ASSEMBLY INSTRUCTIONS CONTINUED

SOLO BED

b) Assembly is now complete and the bed is ready to receive a mattress.

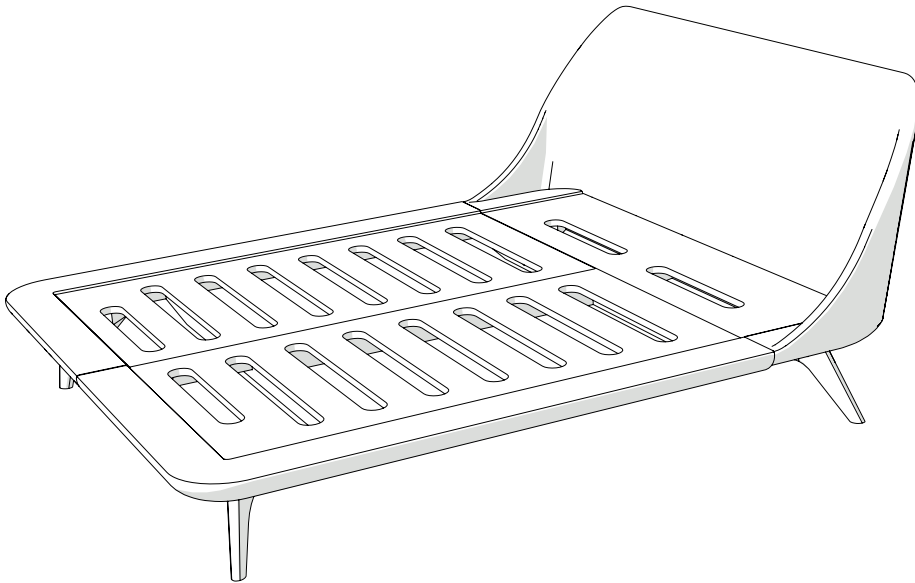

0
8
N
E
R
I
&
H
U