

**ASSEMBLY INSTRUCTIONS**

CAPO BED BY NERI&HU

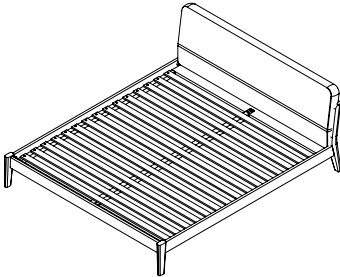

PARTS

- 1x Headboard
- 1x Footboard
- 2x Sidebeams
- 1x Central beam
- 16x Timber slats (NOTE: California King size has 17x Timber slats plus 2x additional M5x40 bolts and washers)

HARDWARE

- (4x) Universal connector with metal dowel
- (4x) M8x25 socket cap screws



- (32x) M5x40 bolts
- (36x) M5 washers



YOU WILL NEED

- 5mm socket/ratchet set OR cordless drill with the appropriate attachment
- 5mm Allen Key
- The help of a friend

NOTES

NOTE 1: Be certain that all assembly is carried out on a flat and stable surface. This will ensure a good final result. Reverse the steps to disassemble the piece.

NOTE 2: Your furniture arrives packed in numerous layers that protect it during transport. It is important that you remove the packaging carefully to avoid damaging your furniture. Refer to our information sheet "Unpacking Your Furniture" for further details.

NOTE 3: Great care is required when assembling our products . Use blankets to soften the assembly surface - hard surfaces such as wood or stone flooring may damage the furniture if in direct contact.

NOTE 4: We advise that assembly and disassembly of De La Espada furniture is undertaken by a minimum of 2 people.

NOTE 5: When screwing in bolts, tighten well, but be sure NOT TO OVERTIGHTEN. This can cause the thread to strip thus resulting in a poor connection.

**ASSEMBLY INSTRUCTIONS CONTINUED**

CAPO BED

NOTE 6: All mating parts are numbered so they correspond to the appropriate part around the frame of the bed. you will ensure the best possible fit if all parts are mated with the corresponding numbered parts. While you work, be sure all connections are flush with no gaps.

0  
2

INSTRUCTIONS

1. ATTACH SIDEBEAMS TO HEADBOARD AND FOOTBOARD

a) Unpack components and set them out so they are in the correct orientation. Check for number markings.

b) Insert the metal dowels into the pre-drilled holes in the headboard and footboard.

c) Insert the Universal Connectors (round metal hardware) into the rebates in the sidebeams.

d) Connect the parts by guiding the metal dowels into the Universal Connectors, then tightening with an Allen Key.

N  
E  
R  
I  
&  
H  
U

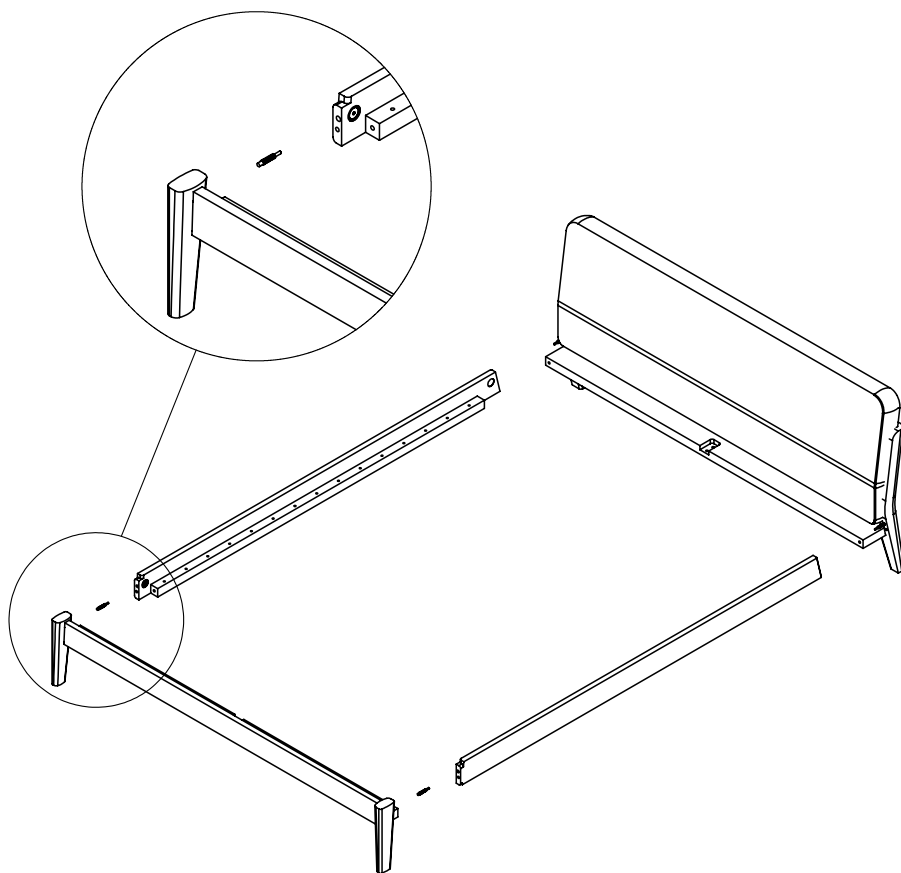

**ASSEMBLY INSTRUCTIONS CONTINUED**

CAPO BED

2. ATTACH CENTRAL BEAM TO HEADBOARD AND FOOTBOARD

- a) Place central beam in position, following number markings.
- b) Place a washer in each of the four recesses in the central beam, then insert the M8x25 socket cap screws and tighten with an Allen Key.

0  
3  
N  
E  
R  
I  
&  
H  
U

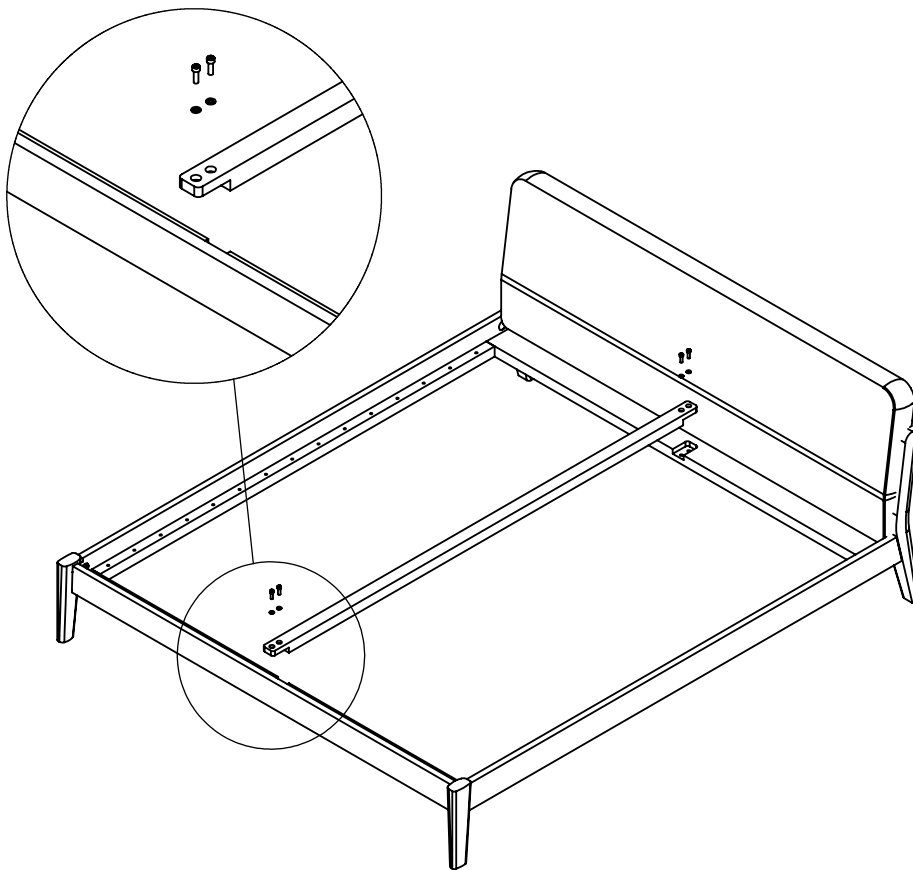

**ASSEMBLY INSTRUCTIONS CONTINUED**  
CAPO BED

3. ATTACH THE TIMBER SLATS TO THE PLATFORM BASE

a) Space out the bed slats so they are aligned with the corresponding holes on the timber lip on the inner face of the side beams. The underside of the each slat has a threaded sleeve fixed inside. If the sleeve drops out, there are spares you can use. The top of each slat has a recess for the washer.

b) Place a washer in the recess of each slat and insert an M5x40 bolt through the slat and into the sidebeam. Using a cordless drill or socket set, tighten the bolts. Tighten the slats well, so they are not wobbly, but be very careful not to overtighten.

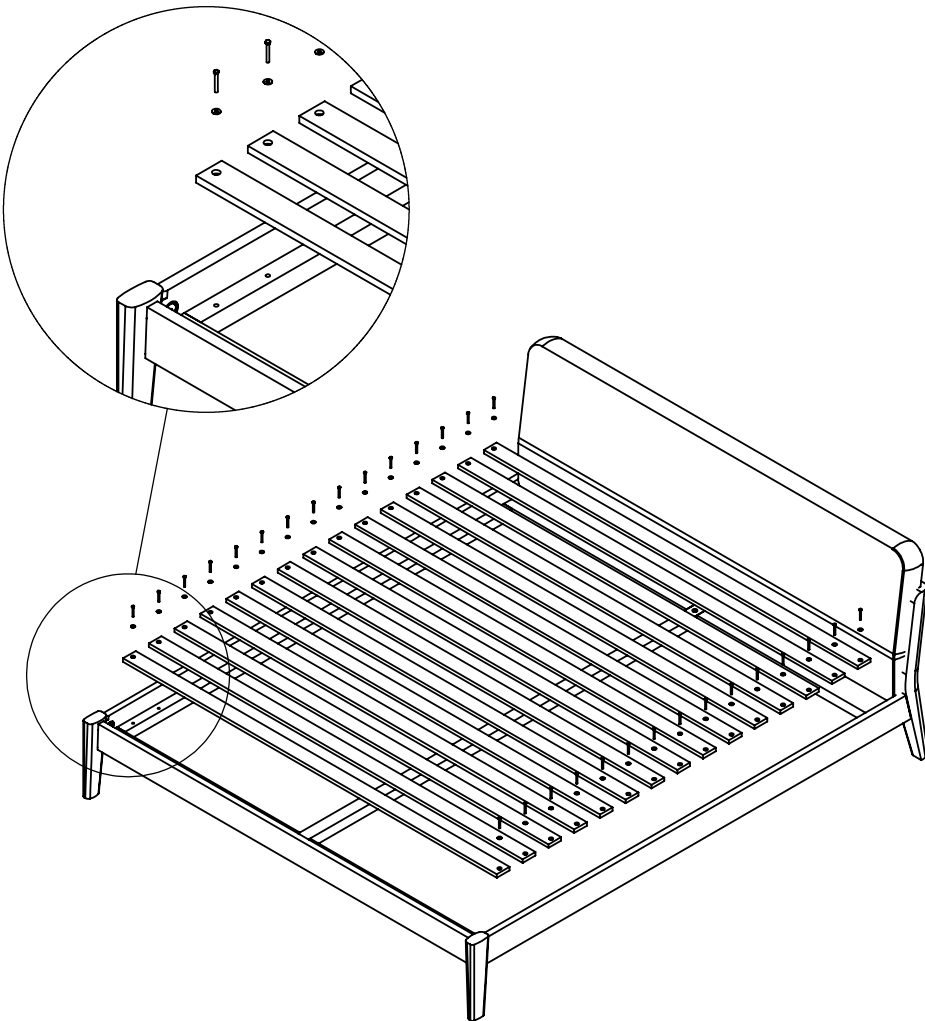

0  
4  
N  
E  
R  
I  
&  
H  
U

**ASSEMBLY INSTRUCTIONS CONTINUED**

CAPO BED

c) Assembly is now complete and bed is ready to receive a mattress.

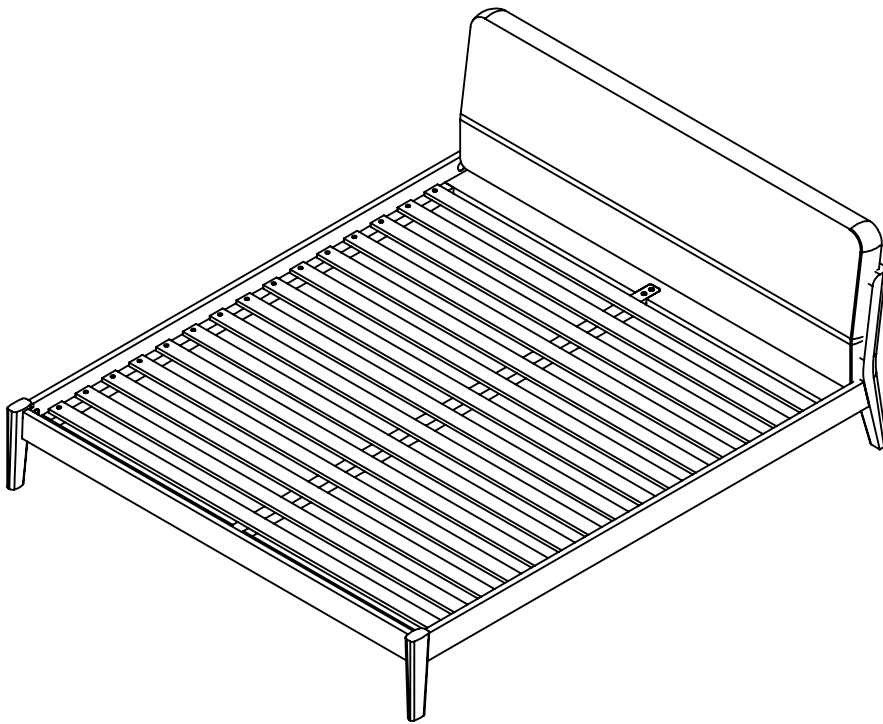

0  
5  
N  
E  
R  
I  
&  
H  
U